

WJC SERIES

BRUSHLESS GEARLESS TRACTION MACHINES OPERATING INSTRUCTIONS

Kinetek DeSheng (Shunde, Foshan) Motor Co., Ltd.
82 Jizhou Shiliang Road, Lunjiao, Shunde District, Foshan City, Guangdong, China

Type code

The code of traction machine is composed of 4 parts. The meaning of each part as following:

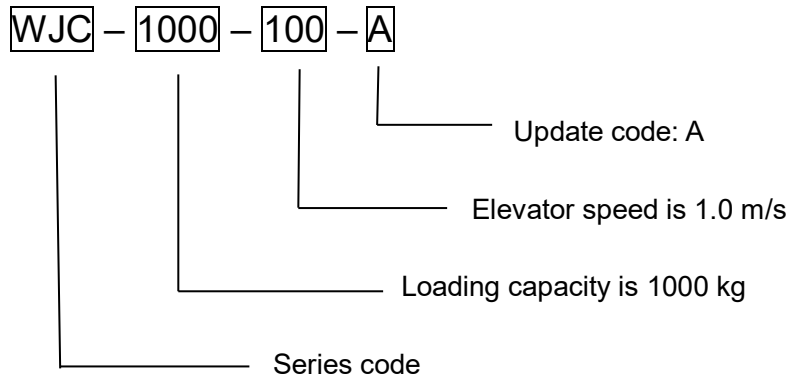

Contents

- 1. Statement -----1**
- 2. Transport and storage-----2**
- 3. Installation-----3**
 - 3.1 General-----3
 - 3.2 Ambient conditions-----3
- 4. Electrical connection-----3**
 - 4.1 General-----3
 - 4.2 Motor and brake connection -----3
 - 4.3 Grounding-----4
 - 4.4 Pulse voltage insulation structure Grounding-----4
- 5. Installation and application of long-distance releasing device-----4**
 - 5.1 Installation-----4
 - 5.2 Application-----5
 - 5.3 Notice-----5
 - 5.4 Hand wheel-----5
- 6. Motor maintenance-----5**
 - 6.1 Bearing maintenance-----5
 - 6.2 Notice-----5
- 7. Install and adjust the brake-----5**
 - 7.1 Notice-----5
 - 7.2 Configuration of the brake-----6
 - 7.3 Adjust the brake-----6
 - 7.4 Maintenance-----8
 - 7.5 Trouble shooting-----9

1. Statement

Only qualified person are allowed to perform any planning, installation or maintenance work. The person must be trained for this job and must be familiar with the installation, assembly, commissioning and operation of the product. Sufficient knowledge in lift construction is essential.

The regulations concerning operation, maintenance and inspection in accordance with the applicable safety regulations in lift construction and other relevant regulations shall be strictly observed.

The operator is responsible for the proper installation of the machine with regard to safety requirements as well as for its inspection and maintenance as specified in the applicable regulations. No liability can be assumed for any damage caused by improper handling or any other acts which are not in conformity with these operating instructions and thus deter form the qualities of the product.

In this manual, the following pictograms are used to mark warning and important notes. These pictograms must be observed.



(Danger) means that death or serious injury to persons or serious damage to property will occur unless the appropriate precautions are taken.



(Warning) means that death or serious injury to persons or serious damage to property may occur unless the appropriate precautions are taken.



(Caution) means that injuries to persons or damage to property may occur unless the appropriate precautions are taken.

The three-phase traction machine are intended for use in an enclosed, lockable machine room to which only qualified personnel and personnel authorized by the client have access.



(Danger) ·The instructions given in this manual or any other instructions supplied must always be observed to avoid dangers or damage.

- Check the proper functioning of the motor and the brake after installing the machine.
- Any adjustment and repair may only be carried out by the manufacturer or an authorized repair agency, unauthorized opening and tampering may lead to injuries to persons and property.



(Warning) ·The machines are not designed for direct connection to the three-phase system but are to be operated via a driver.

- High surface temperatures may occur on the external parts of the machine. Therefore no temperature-sensitive parts may contact these parts or be attached to them. Protection against accidental contact should be provided, if required.
- The proper ability of the brake system should be tested after installing the machine to the lift it

serves and after it's adjustment every time.

- High voltages occur at the terminal connections during the operation of synchronous motors.
- Strictly prohibit from shorting circuit, brake must play the key role while slipping car, short circuit as the help.
- Customers in the purchase of the former must be based on actual operating conditions to confirm the use of tractor capacity and safety factor is to meet the standards
- Hand winding device is for emergency rescue only, It is not allowed for elevator commissioning.
- Please regularly check whether there is oil on brake wheel. If so, please promptly wipe off to prevent brake torque reduction caused by oil.
- Do not overfill the grease otherwise might cause oil leak.

2. Transport and storage

The traction machines leave the factory in a faultless condition after being tested. Make a visual check for any external damage immediately upon their arrival on site. If any damage incurred in transit is found, make a notice of claim in the presence of the forwarder. If necessary, do not put these machines into operation.



(Danger) the eyebolts are designed for the specified machine weight, i.e. it is not permitted to suspend additional loads.

- Store the motors only in closed, dry, dust-free, well ventilated and vibration- free room.
- The time of reserve does not exceed 6 months. Once be exceeded, you should inspect it.
- No liability is assumed for any damage resulting from improper handling of the machine.
- Transportation and storage ambient temperature required: $-25^{\circ}\text{C}\sim 55^{\circ}\text{C}$, and the duration of 24hours on 70°C is supported.
- Make sure the carton is undamaged before opening. Check the nameplate and traction machine is qualified for using.
- Check the packing list first to make sure if all the components are ready after opening the cartoon, whether the machine is damaged, eroding or not.
- Traction machine must be structural-integrity installed, disassemble installation is forbidden.
- Make rope hook clasp the ring on the machine before suspending, and keep steady and no crash during suspending.
- Avoid to damage equipment when suspension.



(Warning) The eyebolts should be fully tightened while lifting, without any gap with frame surface. The angle α between both the eyebolts should be less than 60° .

3. Installation

3.1 General



(Warning) Check the permissible frame or foundation loads by calculation before installing the machine. The frame must be sufficiently rigid to accommodate the bending and torsional forces occurring over the whole load range, Place the machine on a plane surface with a permissible deviation from planeness not exceeding 0.5mm.

Must cover the machine especially brake, when performing any machining or dust-producing work in the well or stand.

Install the machine only in an enclosed machine room and take care to observe the relevant safety precautions.



(Danger) Fasten the machine on the frame with bolts of strength class 12.9

Traction machines are generally provided with rope slip-off guards. After putting the ropes in place, adjust them so that the distance between the rope and the rope slip-off guard does not exceed 1.5mm.

3.2 Ambient conditions

The following ambient conditions must be ensured on site:

- Altitude: max.1000 m, over 1000m need correction according IEC60034-1.
- Ambient temperature: 5°C~40°C
- The deviation between voltage fluctuation and rated voltage does not exceed $\pm 7\%$
- There is no corrosive and flammable gas in environment.
- There are no lubricant and others on the surface of steel wire rope and groove
- Max.rel.humidity:90%.

Install a ventilation equipment to ensure adequate cooling

The Technical data apply to the above ambient temperatures and altitudes.

4. Electrical connection

4.1 General

Make the electrical connection after having installed the motor. Have this done by a qualified electrician. Before starting any work on the motor, and particularly before opening any covers of active parts, make sure that the motor and plant have been properly isolated.



(Warning) Inspection and preparation before the operation:

- **Disconnect the traction machine from the power supply.**
- **Check if the electrical connection is right or not**
- **Affirm there are no short circuit of exposed parts and no short circuit to ground**
- **Earh and short (with voltages above 1,000V)**
 - **Affirm the connection of terminals, inserting connections and bolts are firm enough**

4.2 The traction machine and brake connection

The machine electrical connection component as follows: electrical, grounding, thermoscopethermal , brakes (including micro-switches), all of them in the terminal box. The terminals' connection is showed in box.

4.2.1 Motor connection

The power of the traction machine is supplied by driver, and the U、 V、 W terminals should be connected with the ouput terminals of driver. If the machine can not rotate, change any two terminals between U、 V、 W. The shield of driver and the traction machine should have good earthing.

4.2.2 Connections of brake

The brakes' micro-switch connection diagram is showed showed in box.



(Warning) When the traction machine is used, the temperature monitoring element should

be properly connected to the control system to protect the traction machine from overheating and damage.

4.3 Grounding

For safety reasons, it is very important that the motor be properly and carefully earthed.



(Warning) Use the earthing screw provided on the housing! In addition, connect the protective or earthing conductor in the terminal box.

4.4 Pulse voltage insulation structure

4.4.1 without energy feedback and non-AFE energy feedback, the insulation structure pulse voltage grade: Phase is IVIC C, Ground is IVIC B.

4.4.2 AFE energy feedback, the Max permissible peak-to-peak voltage is as follows:

- Allowable value of phase to phase = $2 \times \text{DC bus voltage} \times \text{Overshoot factor}$
- Allowable value of phase to ground = $0.7 \times 2 \times \text{DC bus voltage} \times \text{Overshoot factor}$

	Phase to phase	Phase to ground
Overshoot factor (OF)	2	1.5

5. Installation and application of long-distance releasing device

The elevator can be lifted through long distance releasing device to save passengers if the power is off or other faults happen. There should be two qualified people to do this. First of all, make sure the power is off, and then do as the following methods. The picture might have some difference with machine because of product improvement just for your reference.

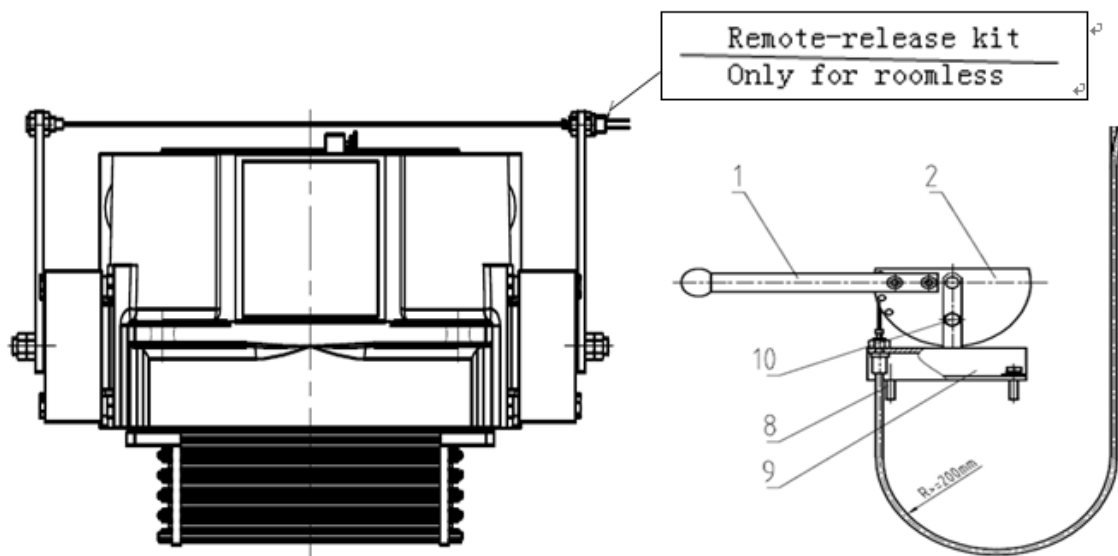

5.1 Installation

- 1) Spread the steel cable .
- 2) Use bolt (8) and spring washer to fix the base (9) on a adequate strength seat



(Warning) There should be some space leaving for curvature of pulling cable on fixing base (bending radius not less than 200mm)

5.2 Application

- 1) Remove locking bolt (10) for plate (2).
- 2) Pull the lever (1) upward, the lever rotates and the brake acts then the traction sheave can be rotated.

- 3) After releasing operation, lock the turn plate (2) with bolt (10) for locking plate in case of suddenness releasing.

If releasing results is not as expected, adjust nut little by little to get releasing function.

5.3 Notice

- 1) When fixing the long-distance releasing device, make sure the pulling cable arranged reasonably and glidingly, with no twist and knot or other situations affect torque transporting. If there need curve the cable, curved radius less than 400mm is advised.
- 2) The user should leave enough space for avoiding the curved radius too small when fixing the releasing base. The curved radius of pulling cable in this place should be less than 400mm, otherwise the release will be hard or even can not release and the cable broken.
- 3) The early fasten force of pulling cable cannot be too high, which can release but won't affect brake torque is ok. If it is too high, this may reduce the brake torque even makes the brake out of work.

Notice:

For the machines without long distance release device, you can use UPS spare power to release brake, slowly roll back and make the car to leveling location.

5.4 Handwheel device instructions

in emergency evacuation you can use the two handles which are delivered with machine to release the brake slowly roll back and make the car to leveling location.



(Warning): When emergency evacuation, please ensure the system power is off.

6. Motor maintenance

6.1 Bearing maintenance

- 1) For bearing with lubrication guidance labels, follow the label instructions for oiling and maintenance; those without lubrication guidance labels do not require grease maintenance.
- 2) For bearings that require lubricant maintenance, customers should inject the same kind of grease. Please do not overfill the grease otherwise might cause oil leak.
- 3) When adding grease, ensure that the oil cup and oil injection hole are clean to prevent dust from entering

6.2 Notice

- 1) Keep the machine room clean and dry.
- 2) Keep the traction machine clean.
- 3) Affirm the brake system is reliable and fray or not.

7. Install and adjust the brake

7.1 Notice

- 1) Before you instal, use and maintain brake, pls. read this manual be carefully to avoid wound or damage equipment, it is necessary to ask qualified trainer to operate this part. Yellow indication——professional can be rectified, red indication ——no adjustment unless the manufacture's guidance.
- 2) According to model number and label instruction to connect power and voltage correctly.
- 3) Prohibit installing or maintaining brake while power on.
- 4) Prohibit to maintenance while machine running.
- 5) Tension is prohibited between the connections wires.
- 6) Please avoid any grease or oil onto brake pads, otherwise, the brake torque will be dropped dramatically.

7) The temperature of brake surface is pretty high, be care to scald.

7.2 Configuration of the brake

NOTE: The picture might some difference with machine because product improvement just for you reference.

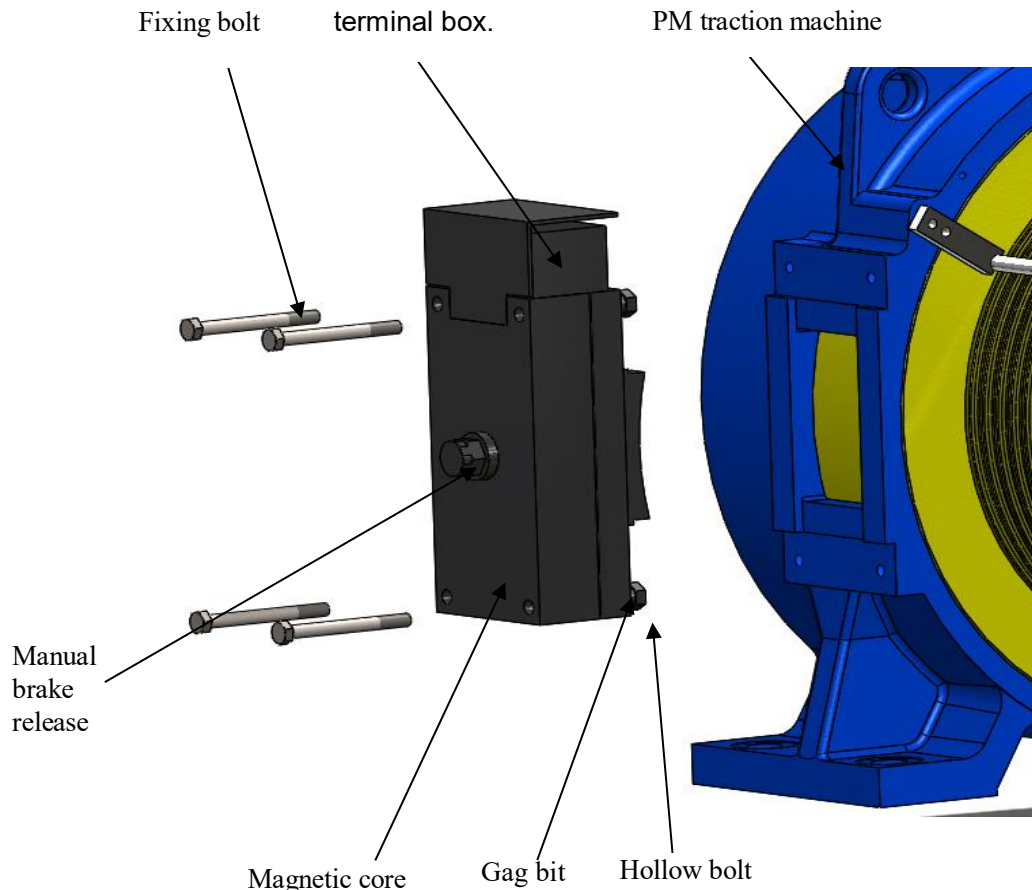

7.3 Adjust the brake

- Air gap adjustment

Install brake to machine, it needs to adjust air gap, instruction as below:

Screw bolt, torque is according to the table 1, use feeler to check between gag bit and iron core, see below drawing:

- 1) If the gap is little too big, use the wrench1 spanner anticlockwise rotates the fixed blot of about 30° to make the blot a little bit loose, and then use the wrench 2 spanner to rotate the blot anticlockwise to make the blot turn into the coil iron core, then rotate the fixed blot clockwise to make it fixed. Use feeler to exam the gad and see whether it meet the standard.
- 2) If the gap is too small, use the wrench1 spanner to rotate the fixed blot 30°-- 40 °to make the blot a little loose, and then use the wrench 2 spanner to rotate the blot clockwise to make the blot withdraw from the coil iron core, then rotate the fixed blot clockwise to make it fixed. Use the feeler to exam the gad and see whether it meet the standard.

	Wrench 1	Wrench 2	Tightening torque (Nm)	Air gap δ (mm)
2X320Nm	Open end wrench 16	Open end wrench 17	45~50	0.35~0.45
2X530Nm				0.35~0.45
2X840Nm				0.35~0.45
2X920Nm				0.35~0.45
2X1400Nm	Hexagon socket wrench 10	Open end wrench 19	80~90	0.35~0.45
2X2300Nm				0.4~0.5
2X2750Nm				0.4~0.5

Table 1

(Notice): 1) Rotate the hollow blot slightly, screw down the 4 fixed blots.

2) The friction pad may have the abrasion after using for sometime, the air gap will be larger, when the air gap comes to 0.6mm, please adjust the air gap and make it reach to brake label.

Check the air gap with standard feeler, the four corners of the brake should be controlled within the allowable range.

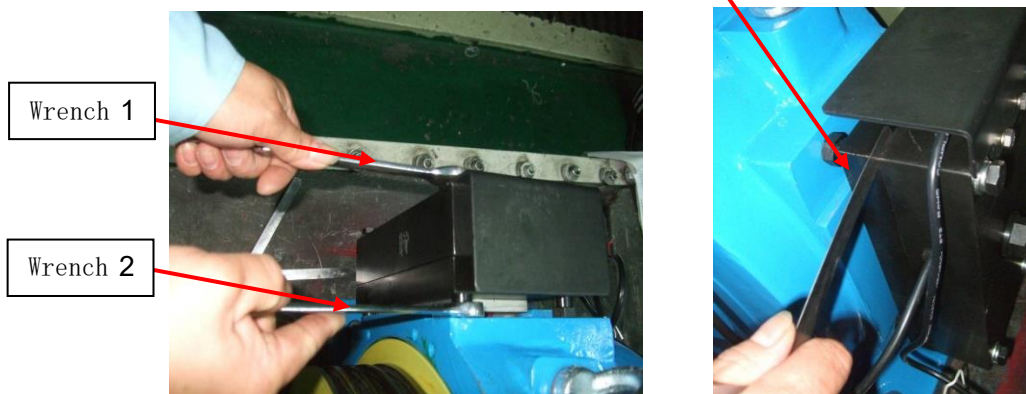

- Adjustmetn to the micro switch

1) Micro swich connetction diagram

2) Micro switch adjust and function test

See the below picture:

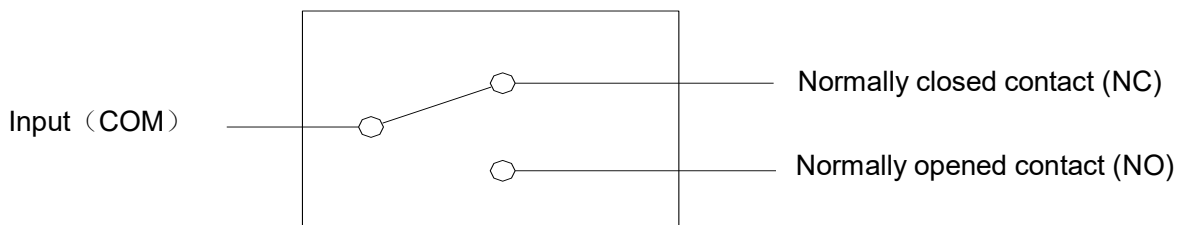

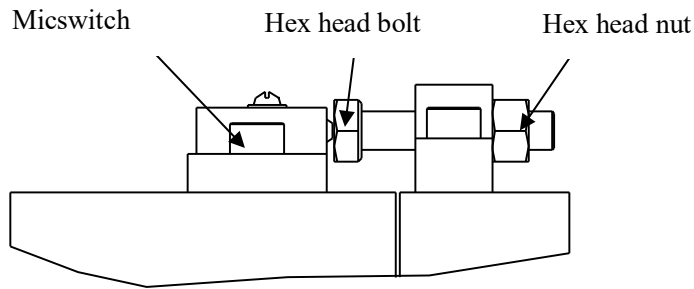

- 1) If it is the first time to adjust the micro switch, please rotate the hex head blot to the switch side, until it touch the contactor of micro switch.
- 2) Put the 0.10mm feeler between the switch contactor and the hex head blot.
- 3) use the luminotron to test and see whether the black wire and the blue wire is connected, if the light is un-light, then rotate the hex head blot to the switch side to make it light, then turn to the other side to make the light un-light, screw down the hex head nuts to fix the hex head blots.
- 4) Electrify the brake, make sure the indicator light is power on, when the brake electricity is cut off, the light is power off.
- 5) Put the 0.10mm feeler between the switch contactor and the hex head blot,the micswith nowork. Put the 0.20mm feeler between the swith contactor and the hex head blot,the micswith work.
- 6) Lacquer every fixed part with the safety lacquer.

7.4 Maintenance

- 1) Fixed check the air gap between brake gag bit and electric magnetic core, if the gap bigger than 0.6, need to adjust it.
- 2) Brake shoe
 - 2.1) If the brake shoe is have cracks or fall off, it must be replaced.
 - 2.2) If “ Δ ” less table 2, the brkae shoe must be replaced.

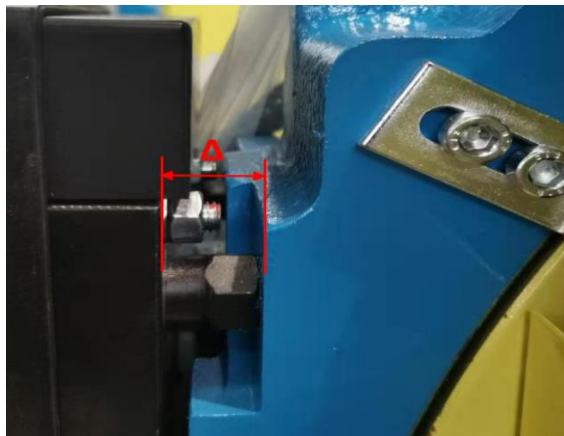

Brake torque	Δ (mm)	Brake torque	Δ (mm)
2X320Nm	12.0	2X1400Nm	10.5
2X530Nm	14.0	2X2300Nm	12.5
2X840Nm	13.5	2X2700Nm	12.5
2X920Nm	13.5		

Table 2

- 3) At least remove brake coil and check 5 years a time.
- 4) Fixed check brake job time.

(Notice): If adjust brake both sides at the same time, should put up the car in empty loading

and sit on the buffer to avoid roll back!

 **(Notice):** If the car didn't sit on the buffer and would like to adjust brake torque and open brake gap, should adjust brake each side separately.

 **(Notice):** Before normal working or electrify testing, should put open brake spanner in place.

7.5 Trouble shooting

1) Brake coil over heat

1.1) Check whether inter-turn is short-circuit, if so, change a new brake.

1.2) Check whether relay contact in controller burnt out or not, if so, handle it in time due to brake working duty is S5-40% which unable to electrify in a long time.

2) Brake friction rotor

2.1) Check whether hollow bolt is closed to frame or not

2.1.1) If not, please use 18mm spanner clockwise rotate hollow bolt and make it closed and fasten. Using feeler to check whether air gap could meet the requirement, please refer to item 8.3 which show you how to adjust air gap, then electrify, problems used to resolve.

2.1.2) Hollow bolt closed to machine frame without loosen, need to check whether air gap is too narrow, if so, adjust it and refer to item 8.3 which show you how to adjust air gap, then electrify and check again.

3) Brake over noise

3.1) Check whether air gap is too large, if so, adjust it and refer to item 8.3 which show you how to adjust air gap, then electrify and check again.

3.2) Check the continued flow loop resistance R whether it is too large, if the release time is meet, the resistance can be reduced under the premise, the noise can be reduced.

4) Brake unable to closing.

4.1) Check whether input voltage is rated voltage, if lower than rated voltage, adjust input voltage.

4.2) Check whether there is magnetism after electrify, could use spanner etc. some tools to check it.

4.3) Check whether air gap is too large, if so, adjust it and refer to item 8.3 which show you how to adjust air gap, then electrify and problems used to resolve.

 **(Notice):** Adjust and maintain hollow bolt and fixing bolt at the same time